

## Contents

1. Assembly drawings
2. Construction and function
  - 2.1 Construction
  - 2.2 Function
3. Torque limiter design
  - 3.1 Choosing the right torque limiter
    - 3.1.1 Dimensioning of the torque limiter
    - 3.2 Interpretation of the torque
      - 3.2.1 For axle drives with reduction gearboxes
      - 3.2.2 For direct drives
    - 3.3 Dimensioning the bore size
  - 4 Adjustment of the disengagement torque
    - 4.1 Preparation of adjustment
  5. Preventive measures
  - 6 Preparation mounting, demounting
    - 6.1 Torque limiters with conical bushing
    - 6.2 Torque limiters with keyway
  7. Fitting of the assembly parts
    - 7.1 Assemblies on type ECA
    - 7.2 Assemblies on type ECB
  8. Supplyment of disc springs as spare parts
  9. Further informations
  10. Maintenance
  11. Supplements
    - 11.1 Warranty
    - 11.2 Safety regulations
    - 11.3 Copy right
    - 11.4 Spare parts
    - 11.5 Proviso

## 1. Assembly drawing

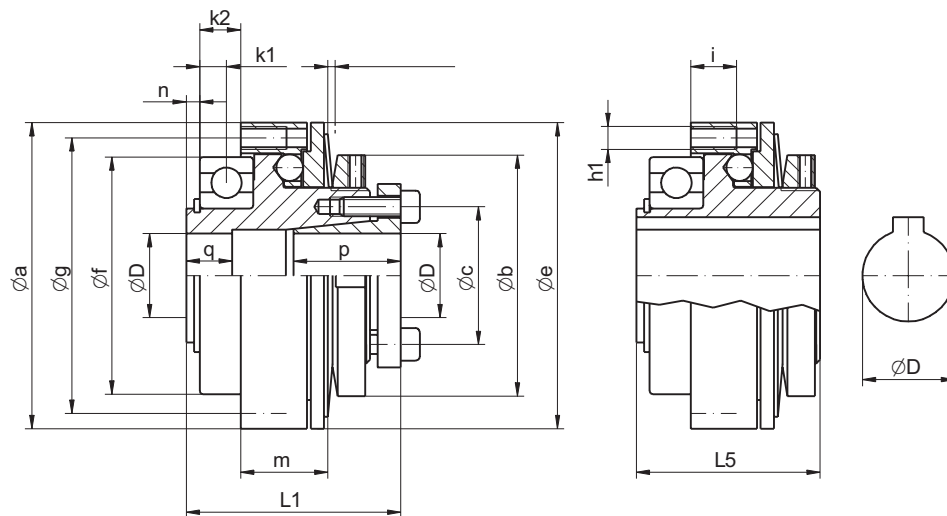

**Torque limiter ECA**

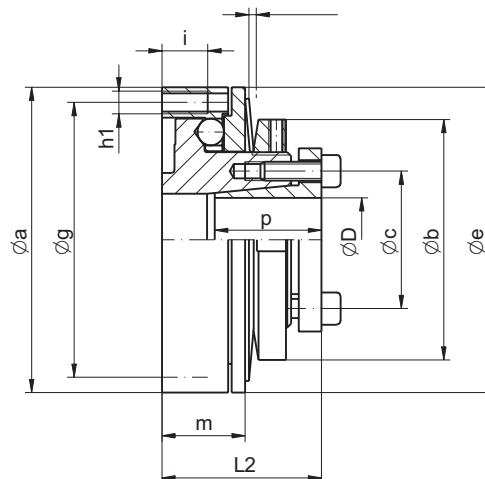

**Torque limiter ECB**

**ENEMAC torque limiters ARE NO safety devices to protect persons from movable parts!**

## 2. Construction and function

### 2.1 Construction

The torque limiter is a mechanical device consisting of only a few components. A spherical ring in which the balls are placed, a plate spring, as well as the hub.

### 2.2 Function

During normal operation of the machine, the balls are pressed into the recesses of the flange ring by the disc spring and thus transfers clearance-free the force or torque from the hub onto the flange ring and vice versa. In case of an overload, the hub distorts against the flange ring and pushes the balls from their indentations against the disc spring - the torque limiter ratchets over - (1 x per revolution as standard) and actuates the proximity switch which has to cut off the drive immediately.

The torque limiter is only designed for short-term clicks! After the disruption has been eliminated, the torque limiter gets turned - at low speed or by hand - (no direction of rotation) and automatically locks in the synchronous position (audible). It is now ready for operation, the adjusted torque active again.

### 3. Torque limiter design

#### 3.1 Choosing the right torque limiter

##### 3.1.1 Dimensioning of the torque limiter

The disengagement torque  $T_A$  of the torque limiter should be set as low as possible in order to effectively limit the overload on the machine. At the same time the maximum torque needs to have an adequate safety factor, which is needed for an immaculate operation of the machine (e. g. high acceleration moments, load peaks during the working cycle).

If you've got problems choosing the right torque limiter, use our coupling configurator on:

<https://compass.enemac.de/home>

#### 3.2 Interpretation of the torque

##### 3.2.1 For axle drives with reduction gearboxes

The following setting value can be expected for CNC machines in most cases:

$$\text{disengagement torque } T_A \text{ (Nm)} = 2,5 \times \text{nominal torque of the motor}$$

This value applies with an usual reduction ratio of the toothed belt transmission of 1.5: 1 or 1.6: 1 and when the torque limiter is installed on the journal of the ball spindle. It also depends on the acceleration torque of the motor and the moments of inertia of the motor and the powered machine parts. The setting value also changes when the torque limiter is mounted on the motor shaft.

##### 3.2.2 For direct drives

The following setting value can be expected for CNC machines in most cases:

$$\text{disengagement torque } T_A \text{ (Nm)} = 1,5 \times \text{nominal torque of the motor}$$

This value is also dependent on the acceleration torque of the motor and the mass moment of inertia of the motor and the powered machine parts.

#### 3.3 Dimensioning of th bore size

The fitting between hub and the shaft has to be selected as sliding seat (eg H7 / j6 or G7 / k6). The bore of the hub has an H7 fit as standard. Keyways according to DIN 6885 page 1.

### 4. Adjustment of the disengagement torque

ATTENTION! The characteristic curve of the disc spring is declining in the setting range.

This means that contrary to the usual habit when rotating the adjusting nut...

- clockwise =>  $T_A$  decreases
- anti-clockwise =>  $T_A$  increases

(See directional arrows on the clamping ring or the adjusting nut)

Torque limiters are pre-set to approx. 70% of the maximum torque when assembled by the manufacturer.

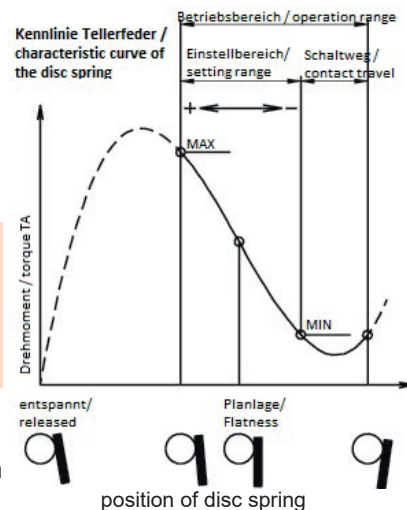

## 4.1 Preparation of adjustment

Unscrew the locking screw completely, turn the adjusting nut with the hook wrench (observe the reference mark). Secure the adjusting nut by twisting the locking screw and possibly by bending it against twisting after the adjustment. The ‚K‘ version is an exception, they are fixed on the disc by means of a stop collar.

The actual TA can only be measured correctly if:

- The torque limiter is assembled with a belt pulley or adapter flange, or
- The installation state is simulated by a measuring device

### clamping hub

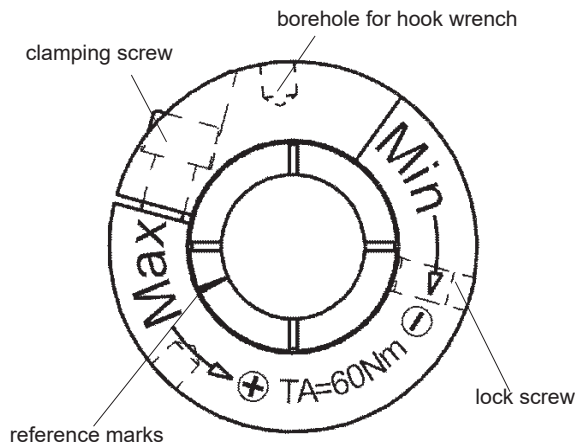

### keyway and conical bushing

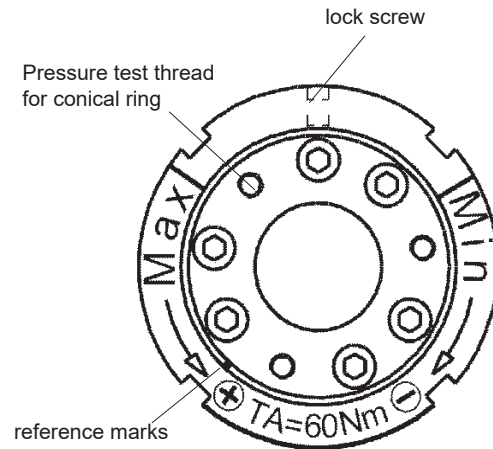

## 5. Preventive measures

Before assembly, it is important to ensure that the characteristics and specifications of the coupling are appropriate and suitable for the intended use. Sufficient space for installation and future maintenance has to be provided. Make sure that the device can not cause dangerous situations for people and / or property and always work under current safety regulations

With regard to the current EU machinery directive, our products are no machines. Therefore, the operation is subject to all requirements of the machine in which the device is installed. If the instructions are carried out incorrectly, this will release the manufacturer from any liability.

ENEMAC torque limiters are mechanical components and protect endproducts against damage in case of a sudden overload during normal use.

The maximum speeds specified in the technical data refer only to the respective torque limiter. If drive elements are being installed which permit lower speed, of course the lowest speed indication is decisive (eg the maximum permissible chain speed).

For questions which can't be answered by this manual, or for special applications, please always contact ENEMAC GmbH.

## 6. Mounting and demounting

### 6.1 Torque limiters with conical bushing

The fitting between conical bushing and the shaft must be selected as a sliding seat, eg H7 / j6 or G7 / k6. By means of keyways in the shaft, the function of the force-fitting connection won't be affected. The screws are slightly tightened when torque limiters with conical bushings are delivered. Before mounting, loosen the screws and the conical bushing to allow the torque limiter to become easily slipped onto the shaft.

When mounting, tighten the screws of the conical bushing uniformly cross-wise to avoid jamming. Too much axial runout, especially with the ECB type, causes the belt pulley to jam and clamp. In case of a breakdown, it can't slip through and therefore the torque limiter can't shutdown. For tightening torques see data sheets.

After loosening the 6 fastening screws, loosen the hub by 3 pushing threads in the conical bushing. In case of axially tight conditions, it is advisable to screw in the release screws during assembly and to lock against the hub after tightening the fastening screws.

When disassembling, loosen the fastening screws and detach the conical bushing from the hub using the 3 pushing threads, as shown in the figure.

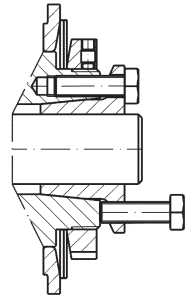

## 6.2 Torque limiters with keyway

The fitting between hub and shaft has to be chosen as sliding seat, e. g. H7/j6 or G7/k6. Keyways according to DIN 6885 sheet 1.

## 7. Fitting of the assembly parts

### 7.1 Assemblies on type ECA

The axial centers of the toothed belt pulley and ball bearing are aligned so that the tensile force of the toothed belt is directly supported by the bearing.

The dimension,  $k_2$ , must be produced with the tolerance,  $+0.1 \text{ mm}$ . The stop collar on the outer ring of the ball bearing must be at least 3 mm wide, so that both parts lie reliably planar.

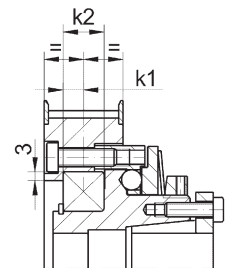

### 7.2 Assemblies on type ECB

The entire torque limiter-side surface of the toothed belt pulley must be planar. ECB and belt pulley are both centered on the shaft and must not be centered with each other by a fitting.

## 8. Supplyment of disc springs as spare parts

Generally, our torque limiters have to be returned to our factory for repair or reconstruction. Only for torque limiters which have been rebuilt or repaired by ENEMAC GmbH, a functional guarantee can be applied.

Disc springs may only be delivered as a spare part if a return of the relevant torque limiter is not possible and the customer explicitly rejects the delivery of an exchange torque limiter.

**In this case, our warranty deed expires!**

## 9. Further informations

### Safety shutdown

In case of an overload, the drive must be switched off immediately. Normally, the switch plate activates a proximity switch, which is arranged in axial direction (see installation instructions in the catalog) and directly interrupts the circuit of the motor. The couplings are designed for 250 overload shutdowns.

### Installation on vertical axes

Please note that the ENEMAC torque limiter in standard version only applies a small residual moment after disengagement, which is normally NOT sufficient to prevent the machine axis from sliding. A special version is necessary for this!

## **10. Maintenance**

Maintenance work on the torque limiter is required to restore the disengagement torque of the coupling, as the discs will fade with frequent stress. To do this, adjust the adjusting nut by turning it. (See point 4 of the operating manual)

Repairs may only be carried out by ENEMAC GmbH, or the guarantee will expire!

## **11. Supplements**

### **11.1 Warranty**

The warranty period is 12 months starting with date of delivery when used in the intended one-shift operation, or max. 250 shutdowns. The warranty does not cover damage caused by improper operation. Any warranty claims are determined by repair or intervention, carried out by unauthorized persons and the use of utilities and spare parts, which aren't matching our torque limiters.

### **11.2 Safety regulations**

Regardless of the instructions listed in this manual, the German statutory safety and accident prevention regulations are valid. Any person who is responsible for the operation, maintenance and repair of the torque limiter must have read and understood the operating instructions before commissioning. Repairer of the torque limiters are basically responsible for workplace safety. Following all valid safety and regulatory instructions is a requirement to prevent damages to persons and the product during maintenance and repair work. Proper repair of ENEMAC products assumes accordingly trained staff. The duty of training is up to the operator or repairer. It is to ensure that the operator and future repairer are properly trained for the product.

### **11.3 Copy right**

This operating instructions manual is copyrighted property of ENEMAC GmbH. It is only delivered to our customers and users of our products and is supplied with the torque limiter. Without our explicit approval these documents mustn't be reproduced nor made available to third persons in particular competitive companies.

### **11.4 Spare parts**

Only spare parts, which correspond to the requirements specified by ENEMAC GmbH or supplier are allowed. This is always guaranteed with original spare parts. Improper repairs, as well as incorrect spare parts lead to the exclusion of product liability or warranty. When ordering spare parts it is essential to specify type, size and the identification number of the torque limiter to avoid incorrect deliveries.

### **11.5 Proviso**

We reserve the right for technical changes. Changes, errors and misprints shall not justify any titles of indemnity.