

Operating Manual Metal Bellows Couplings EWA, EWB, EWC, EWF



Content

1. Assembly drawings
2. Construction and function
 - 2.1 Construction
 - 2.2 Function
3. Dimensioning of the coupling
 - 3.1 Definitions
 - 3.2 Dimensioning according to the torque
 - 3.3 Dimensioning according to torsional stiffness
 - 3.4 Dimensioning according to the bore size
 - 3.5 Lifetime of the coupling
 - 3.6 Maximum load
 - 3.7 Load of the bearings
 - 3.8 Operating temperature
 - 3.9 Operating speed - balance quality
 - 3.10 Maintenance and wear
4. Dimensioning of the bore sizes
5. Dimensioning of the torque
 - 5.1 Formula
6. Precausal measures
7. Mounting and demounting
 - 7.1 Aligning the shafts
 - 7.2 Shaft-hub-connection
 - 7.3 Demounting
 - 7.4 Notes
8. Maintenance
9. Supplements
 - 9.1 Warranty
 - 9.2 Safety regulations
 - 9.3 Copy right
 - 9.4 Spare parts
 - 9.5 Provisio

1. Assembly drawings:

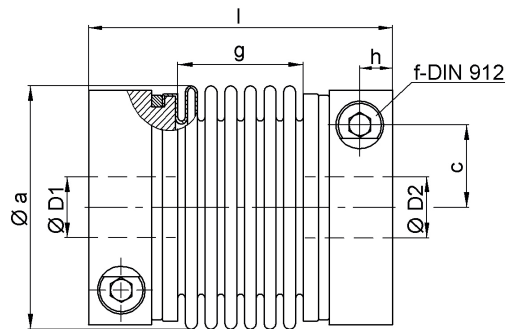

Metal bellows coupling EWA

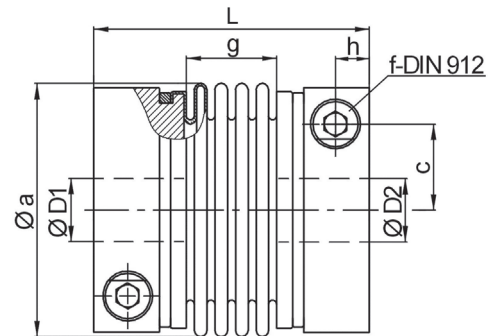

Metal bellows coupling EWB

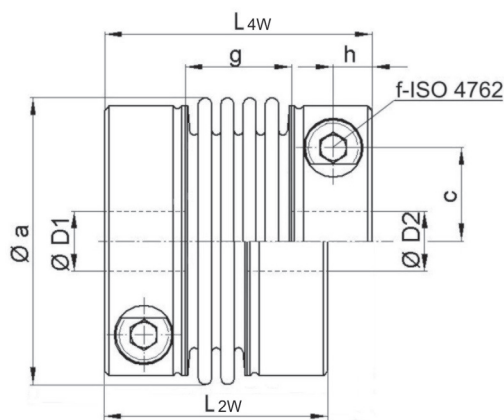

Metal bellows coupling EWC

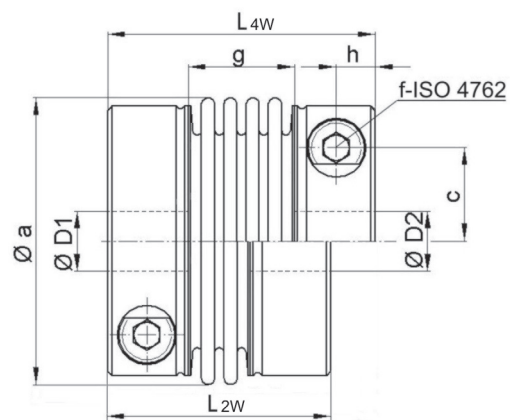

Metal bellows coupling EWF

2. Construction and function:

2.1 Construction:

The metal bellows coupling consists of three main components, two hub parts and a bellows. The types EWA and EWB are equipped with a radial clamping hub made of high-strength aluminum on both sides, the type EWF has radial clamping hubs made of steel on both sides, while the type EWC consists of stainless steel. Stainless steel bellows are used in all variants.

2.2 Function:

Metal bellows couplings are compensating couplings for the backlash-free, angularly accurate transmission of torques with the highest possible torsional rigidity and the lowest possible mass moment of inertia. A metal bellows serves as a connecting and compensating element. It can compensate axial, lateral and angular shaft misalignments.

3. Dimensioning of the coupling:

3.1 Definitions:

a) Nominal torque of the coupling: T_{KN} [Nm]

The nominal torque of the coupling indicates the limit load of the fatigue strength. If T_{KN} is not exceeded in normal operation, an infinite number of work cycles can be carried out (see also 3.5 Lifetime of the coupling).

b) Moment of inertia: J_K - [10^{-3} kgm²]

The coupling values for the mass moment of inertia apply to mean hub bores in the specified diameter range D_{min} / D_{max} .

Conversion: [$kgcm^2$] = [10^{-4} kgm²]

c) Torsional stiffness: C_{TK} - [Nm / arc min]

When specifying the specific torsional stiffness (torsional stiffness) of all coupling series, the previous unit specification [103 Nm / rad] was changed to the unit "Newton meter per angular minute". This enables the designer to determine the resulting torsional angle errors based on the operating torque easily (see 3.3). 60 arc minutes correspond to one degree of angle. This results in the following conversion factor:

$$\begin{aligned} 1 \text{ rad} &= 57,3^\circ = 3438 \text{ arcmin} \\ [10^3 \text{ Nm/rad} &= 0,291 \text{ Nm/arcmin}] \text{ resp.} \\ [1 \text{ Nm/arcmin} &= 3438 \text{ Nm/rad}] \end{aligned}$$

Example: Size EWA 170: 17,5 Nm/arcmin = 60 kNm/rad

d) Maximum Misalignment: [mm]

Largest dimension of the permissible misalignment between the input and output shaft resulting from the fatigue strength calculation for the compensation elements. An infinite number of load changes can be carried out when operating below the permissible offset values. In exceptional cases (e.g. assembly) or with a reduced number of load changes, the offset values may in some cases be significantly higher (please contact us).

e) Lateral- and parallel offset:

If the permissible offset value is significantly exceeded, excessive wear of the metal bellows can occur. Pay particular attention during assembly!

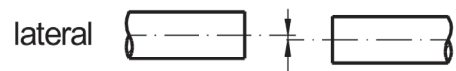

f) Axial offset:

Mostly unproblematic (thermal expansion)

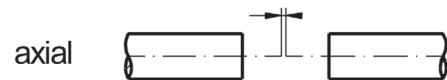

g) Angular offset:

Mostly unproblematic - the maximum permissible value is 1 to 2 degrees.

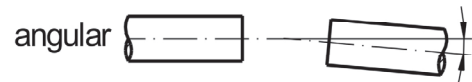

h) Spring rate- axial / lateral: [N/mm]

Restoring forces of the metal bellows resulting from misalignments.

3.2 Dimensioning according to the torque:

Usually, the coupling size is selected based on the torque. For the exact determination of the required torque, complex calculations usually have to be carried out. Once the size of the motor has been designated, the required nominal coupling torque can be roughly determined as follows:

$$T_{KN} > 1,25 \times TA_{max} \times i$$

TA_{max} = Peak motor torque

i = Gear ratio or gear reduction of the toothed belt drive or spur gear

3.3 Dimensioning according to torsional stiffness:

In case of high demands on accuracy (positioning, encoder system), transmission errors due to excessive elastic deformation of the coupling can be a selection criterion. The angle of rotation „ αT “ resulting from the torque load can be calculated as follows:

$$\alpha T = \frac{TA}{C_{TK}}$$

[arcminutes] with TA = nominal torque [Nm] / C_{TK} = torsional stiffness of the coupling [Nm/arcmin]

3.4 Dimensioning according to the bore sizes:

Generally, after the coupling type has been determined, the specified shaft diameter should be checked with the permissible diameter range (D_{min} / D_{max}) of the hub bore. If the shaft diameter is oversized in relation to the torque, i. e. is greater than D_{max} of the hub, another coupling type or size has to be selected.

Note: Bore sizes smaller than D_{min} are possible; however, reliable transmission of the nominal torque is not guaranteed, i. e. a reduction in T_{KN} is required.

3.5 Lifetime of the coupling:

The lifetime of the compensating coupling is essentially determined by the amount of torque and the existing shaft misalignments or offsets. If the maximum permissible values for the axial, lateral and angular misalignment are not exceeded and the operating torque is below the nominal coupling torque T_{KN} , the coupling is in the range of fatigue strength.

Continuous operation around the clock is possible, or an infinite number of acceleration and deceleration phases can be carried out without an operational failure of the coupling being expected.

3.6 Maximum load:

In exceptional cases, the metal bellows couplings can be temporarily overloaded by a maximum of 100% ($2 \times T_{KN}$). The respective shaft-hub connection should, however, be calculated separately.

3.7 Load of the bearings:

Due to the flexibility of the compensating couplings in all directions, significant bearing loads or restoring forces are avoided despite possible axial, lateral or angular displacements from the input to the output shaft. This prevents premature failure or increased wear of the roller bearings, which significantly reduces time-consuming and expensive repairs.

3.8 Operating temperature:

The application limit of the metal bellows couplings EWC and EWF is 623 K; EWA and EWB can be used up to 473 K; high operating temperatures must be taken into account with a corresponding correction factor.

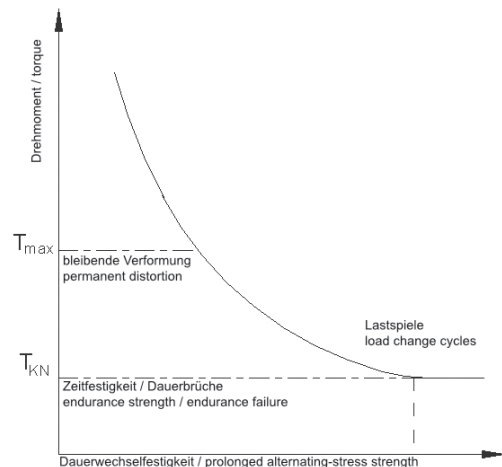

3.9 Operating speed - balance quality:

Due to the precise production and the rotationally symmetrical structure, or the additional balancing pin, the compensating couplings are generally suitable for high speeds of up to 20,000 rpm without balancing. The standard balancing grades are around Q6.3 or Q16.

3.10 Maintenance and wear:

The compensating couplings are maintenance-free and wear-free under normal conditions.

4. Dimensioning of the bore sizes: (ØD1 und ØD2)

The fit between hub and shaft is designed as a transition fit, whereby the bore of the hub has an H7 fit.

5. Dimensioning of the torque:

5.1 Formula:

The required coupling torque T_K can be roughly calculated using the following formula:

T_A = nominal torque [Nm]
 f_B = service factor

$$T_K = T_A \times f_B < T_{KN}$$

Service factor:

Due to the service factor f_B (1.5-2.5), application-specific features, such as shock loads, must be taken into account.

The calculated coupling torque T_K should not exceed the nominal torque of the selected coupling size T_{KN} . Brief overloads to twice the value of the nominal torque are permissible. The drive torque results from the manufacturer's specifications for the drive motor or can be calculated using the drive power P_A .

T_A = nominal torque [Nm]
 P_A = drive power [kW]
 n_B = operating speed [min⁻¹]

$$T_A = \frac{9550 \times P_A}{n_B}$$

6. Precautional Measures:

Before assembly, make sure that the characteristics and specifications of the coupling are adequate and suitable for the intended use. There has to be enough space for installation and future maintenance. Make sure that the device can not cause dangerous situations for people and / or property and always work under the current safety regulations.

With reference to the current EU Machinery Directive, our products are NO Machines. Operation is therefore subject to compliance with all requirements of the machine in which the device is installed. Inaccurate performance will relieve ENEMAC GmbH of all liabilities.

For questions which can not be answered by this manual, or details on special applications always contact ENEMAC GmbH.

7. Mounting and demounting:

7.1 Aligning the shafts:

Axial and angular misalignment are usually unproblematic and also easy to measure. In order to determine the lateral misalignment, it is recommended to proceed as follows: Place a dial indicator with a suitable holder on a shaft journal or on the second coupling half. Now the shafts are turned with the dial gauge and the deflection read off. The existing parallel offset is half of the total range. The maximum permissible values for the shaft misalignments must be taken from the technical data sheets of the corresponding series.

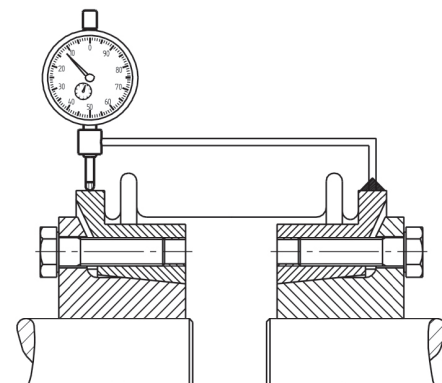

Picture: Alignment of shafts

7.2 Shaft-hub-connection:

The couplings are usually supplied with finished bores, in exceptional cases also pre-bored. The shaft / hub fit must be selected as a transition fit (example: hub bore diameter 28 G6 / shaft diameter 28 k6). In general, it must be ensured that the surface of the shaft and the hub bore is free of oil and grease and cleaned of dirt particles. If there is a keyway in the shaft, the function of the force-fit connection is not impaired (if necessary insert a half key).

Chamfered edges on the front sides also allow blind installation for all versions.

Radial clamping hub:

Permissible clearance between shaft and hub: min. 0.01 mm / max. 0.04 mm. The assembly is very easy to carry out by tightening only one radially arranged clamping screw (ISO 4762). The values for the corresponding tightening torques can be found in the data sheets. A hole in the bell housing is sufficient to tighten the clamping screw.

Tightening torques of the clamping screws:

in Nm:

M2,5	M3	M4	M5	M6	M8	M10	M12	M14	M16
1	2	4	8	14	35	65	115	180	290

Attention: Different tightening torques apply for some series or sizes. See data sheet for this

Loosening torque of the clamping screws:

in Nm:

M4	M5	M6	M8	M10	M12	M14	M16
3	5	8	15	20	25	25	30

7.3 Demounting:

To remove the metal bellows coupling, the clamping screws are loosened using a torque wrench. In special cases, a commercially available Allen key can also be used.

Please note the loosening torques under point 7.2

The types EWA, EWB and EWF are also equipped with an assembly-friendly clamping system (see following pictures).

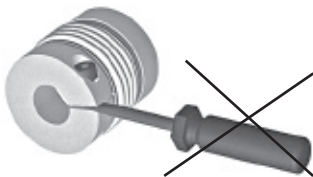
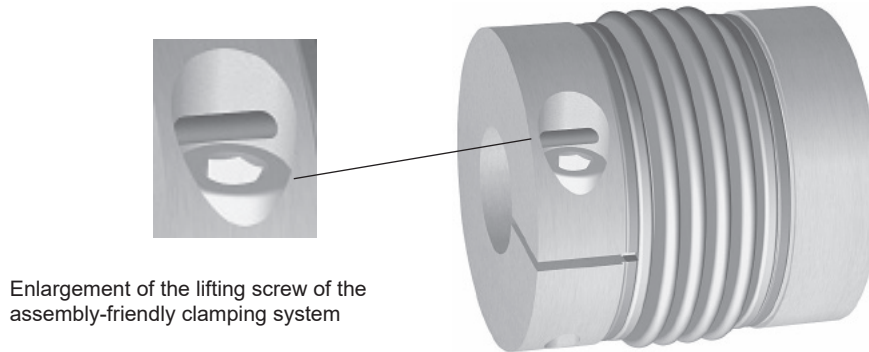

- No additional tools required
- No damage of the hub bore
- No destruction of the coupling when demounting

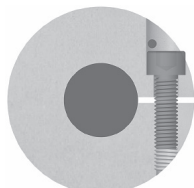

The clamping hub is connected to the shaft free of clearance and force fitting

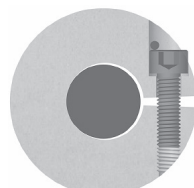

The coupling clamping hub gets elastically expanded for assembly

7.4 Notes:

Since the metal bellows are made of thin stainless steel sheet, special care is required during assembly and disassembly. Damaged bellows could result in defect couplings. Bore sizes smaller than D_{\min} are possible, but a secure torque transmission is not guaranteed. With smaller shaft diameters, the conical hubs (larger wall thickness) are additionally slotted. Further type-related details can be found in the data sheets.

8. Maintenance:

The couplings are maintenance-free. However, it is recommended to check the alignment and tightening torque of the bolts and nuts after the first hours of operation and at regular intervals thereafter.

9. Supplements:

9.1 Warranty:

The warranty is 12 months from the date of delivery; when used as intended in 1-shift operation. The warranty claim expires if damage is caused by improper use. Repair work or interventions carried out by unauthorized persons and the use of accessories and spare parts for which our metal bellows couplings are not matched lead to the expiry of any warranty claims.

9.2 Safety regulations:

Regardless of the instructions listed in this manual, the German statutory safety and accident prevention regulations are valid. Any person who is responsible for the operation, maintenance and repair of the metal bellows couplings must have read and understood the operating instructions before commissioning. Repairer of the metal bellows couplings are basically responsible for workplace safety. Following all valid safety and regulatory instructions is a requirement to prevent damages to persons and the product during maintenance and repair work. Proper repair of ENEMAC products assumes accordingly trained staff. The duty of training is up to the operator or repairer. It is to ensure that the operator and future repairer are properly trained for the product.

9.3 Copy right:

This operating instructions manual is copyrighted property of ENEMAC GmbH. It is only delivered to our customers and users of our products and is supplied with the metal bellows coupling. Without our explicit approval these documents mustn't be reproduced nor made available to third persons in particular competitive companies.

9.4 Spare parts:

Only spare parts, which correspond to the requirements specified by ENEMAC GmbH or supplier are allowed. This is always guaranteed with original spare parts. Improper repairs, as well as incorrect spare parts lead to the exclusion of product liability or warranty. When ordering spare parts it is essential to specify type and size of the metal bellows coupling to avoid incorrect deliveries

9.5 Provisio:

We reserve the right for technical changes. Changes, errors and misprints shall not justify any titles of indemnity.